

# LIFEBREATH® 267 MAX ERV-FID

Indoor Air Systems ENERGY RECOVERY VENTILATOR



267 MAX ERV-FID  
278 CFM @ 0.3 (75) IN. W.G. (PA)



## BRINGING COMPACT TO A WHOLE NEW LEVEL

- AUTO BALANCING
- DXPL03 Digital Wall Control included, for easy programmability.
- Damper recirculating defrost cycle
- Top port 6" oval duct
- Square ERV core
- High efficiency EC motors
- -25°C HVI Cold Weather Certified

NOTE: Front clearance of 22 in. (559 mm) is recommended for servicing unit.  
All ducts use 6 in. (152 mm) round collars.  
All units conform to CSA and UL standards.

## DIMENSIONS

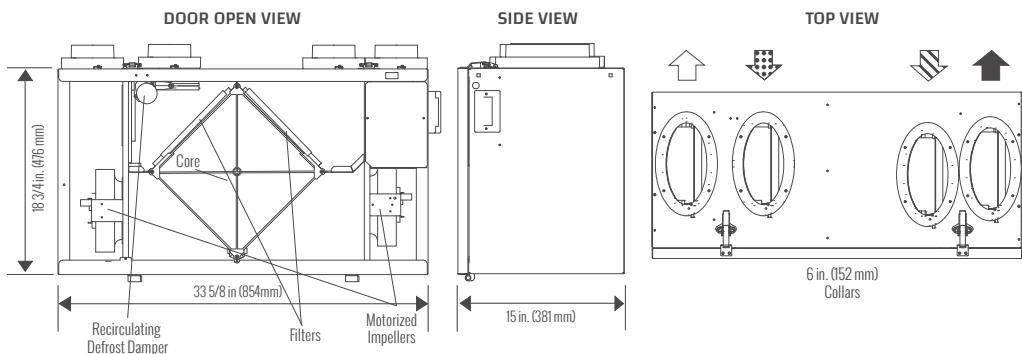

## FEATURES

### AUTO BALANCE

DXPL03 control allows airflow to be selected for both supply and exhaust air streams. Live air pressure measurements enable automatic and continuous adjustment of fan speeds to ensure constant user selected airflow.

### FAULT INDICATION DISPLAY (FID)

Title 24 Compliant. A FID enabled HRV or ERV is capable of displaying error codes for certain types of faults which impact operation of the system.

### TOTAL RECOVERY CORE

Cross-flow energy recover core transfers heat and water vapor between two airstreams. Easily removed for cleaning or service.

### MOTORS AND BLOWERS

Each airstream has an independent EC motorized impeller with multiple fan speed operation.

### MERV 6 FILTERS

Washable air filters in exhaust and supply airstreams.  
MERV 13 Upgrade: 65-195-6R.

### MOUNTING

Adjustable hanging straps supplied.

### DEFROST

Temperature sensor activated recirculation damper defrost. Intelligent energy-efficient DC motorized damper with integrated Ice Breaker technology.

### CASE

22 gauge prepainted galvanized steel for superior corrosion resistance, insulated to prevent exterior condensation.

Weight: 57 lbs (25.8 KG) • Shipping Weight: 67 lbs (30 KG)

# LIFEBREATH® 267 MAX ERV-FID

Indoor Air Systems ENERGY RECOVERY VENTILATOR



## SPECIFICATIONS

<b>MODEL:</b>	<b>267 MAX ERV</b>
<b>VOLTAGE:</b>	120 V
<b>FREQUENCY:</b>	60 Hz
<b>WATTS @ 64 CFM (30 L/S):</b>	30 W
<b>CURRENT:</b>	4.5 A
<b>AIRFLOW @ 0.3:</b>	278 CFM
<b>WEIGHT:</b>	57 lbs / 25.8 kg
<b>DRAIN:</b>	Optional
<b>MCA:</b>	7.0 A
<b>MOP:</b>	15 A
<b>WARRANTY:</b>	Units carry a 5 year warranty on the ERV core and a 5 year replacement parts warranty.

## PERFORMANCE

IN. W.G. (PA)	0.2 (50) CFM (L/s)	0.3 (75) CFM (L/s)	0.4 (100) CFM (L/s)	0.5 (125) CFM (L/s)	0.6 (150) CFM (L/s)	0.7 (175) CFM (L/s)	0.8 (200) CFM (L/s)	0.9 (225) CFM (L/s)
<b>Net Supply Airflow</b>	286 (135)	278 (131)	271 (128)	263 (124)	254 (120)	246 (116)	237 (112)	229 (108)
<b>Gross Supply Airflow</b>	290 (137)	282 (133)	273 (129)	265 (125)	259 (122)	250 (118)	239 (113)	231 (109)
<b>Gross Exhaust Airflow</b>	284 (134)	278 (131)	271 (128)	263 (124)	256 (121)	248 (117)	239 (113)	231 (109)

**Sensible Effectiveness (ASE)  
@ 64 CFM (30 L/s)**      32°F (0°C)      85%

**Sensible Efficiency (SRE)  
@ 64 CFM (30 L/s)**      32°F (0°C)      77%

**Sensible Efficiency (SRE)  
@ 74 CFM (35 L/s)**      -13°F (-25°C)      56%

