



700 DD / 700 FD

COMPACT AND RELIABLE UNIT FOR INSTALLATION IN TIGHT LOCATIONS

[AVAILABLE IN DAMPER DEFROST (DD) AND FAN DEFROST (FD)]

- Contains 2 AHRI 1060 Certified 68-222 HEX Cores
- Reversible access, E-box can be located on either side
- Microprocessor circuit board with built in interlock contacts
- Field reversible

NOTE: Service clearance of 30 in. (765 mm).
All units conform to CSA and UL standards.

DIMENSIONS

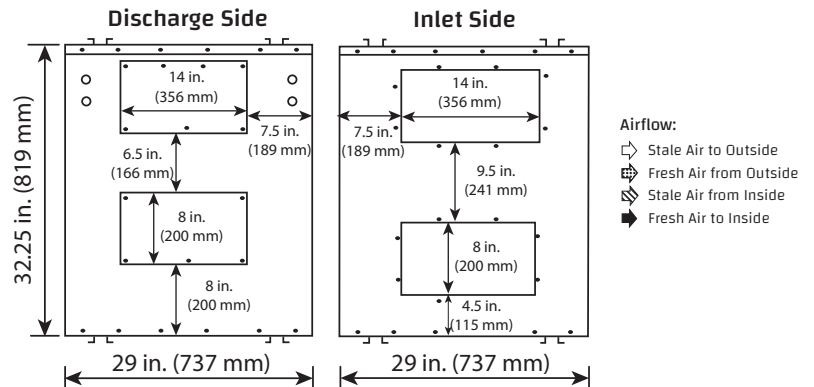
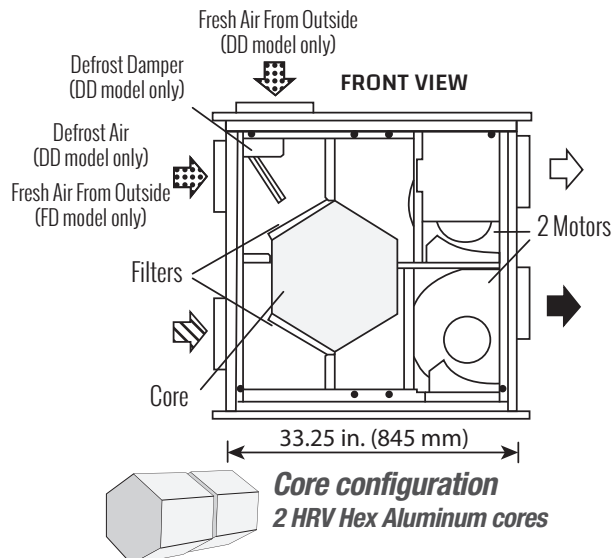

FEATURES

CORES

Modular (2 section) patented aluminum heat recovery cores arranged for efficient counter-flow ventilation.

MOTORS

Two PSC, 3 speed single shafted, 120 VAC, 4.5 Amps each (9 total on high speed). HP-1/4, 1450 RPM. MCA: 11.3 MOP: 15 Watts -total on high speed - 1032.

BLOWERS

Easily slide in/out of unit. Centrifugal type rated at 700 CFM (329 L/s) free air delivery. Each airstream has one single shafted motor driving a centrifugal blower.

MERV 6 FILTERS

Washable air filters in exhaust and supply air streams.
MERV 13 Upgrade: 65-195-6R.

MOUNTING

Unit to be set on support brackets hung by threaded rod-type apparatus (brackets and rods not included)

DEFROST

700 DD - 5th port damper routes indoor air to defrost core.
700 FD - Interrupts supply air while exhaust air defrosts core.

CONNECTION DUCT SIZES

Four - 14 in. x 8 in. (356 mm x 200 mm).

CASE

Unit has front and back access doors and electrical panel can be switched to either side giving the installer flexibility in duct direction. 22 gauge prepainted galvanized steel (G60) for superior corrosion resistance. Insulated with foil faced insulation where required to prevent exterior condensation. Drain connections are two - 1/2" (12 mm) O.D.

ELECTRONICS

Integrated microprocessor circuit board. Built-in interlock contacts.

WARRANTY

Units carry a 15 year warranty on HRV core and 2 year replacement parts warranty.

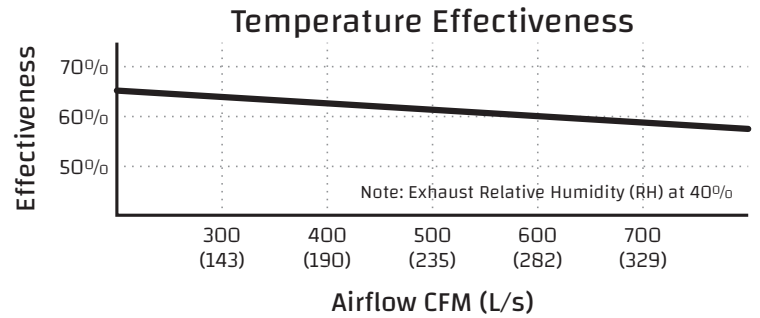
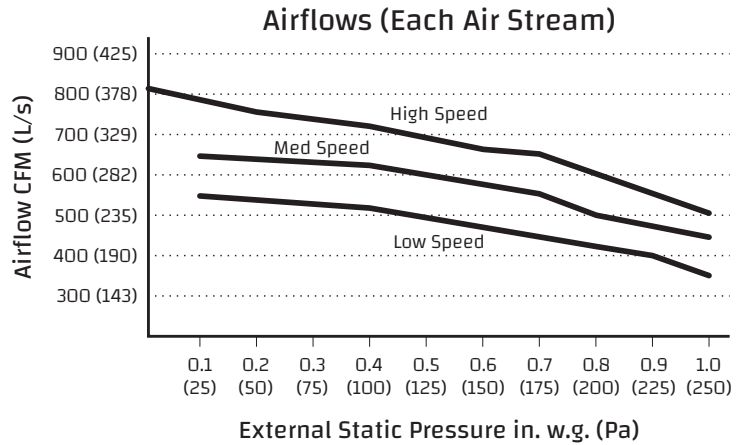

PERFORMANCE

MODEL	DIMENSIONS H x W x D (in.)	DEFROST SYSTEM	EFFECTIVENESS @ 0°C (32°F)	NOMINAL AIRFLOW @ 0.5	# OF CORES / # OF PASSES	# OF SPEEDS	VOLTAGE VAC/PHASE	TOTAL AMPS	MCA / MOP	FILTER MERV RATING
700 DD	32.25 x 33.25 x 29	5th Port Damper	59%	700	2 / 1	3	120/1	9	11.3 / 15	6
700 FD	32.25 x 33.25 x 29	Supply Fan Shutdown	59%	700	2 / 1	3	120/1	9	11.3 / 15	6