



METRO 120 ERV-ECM-AB
117 CFM @ 0.3 (75) IN. W.G. (PA)



BRINGING COMPACT TO A WHOLE NEW LEVEL

- Designed for high-rise condos, apartments and townhomes with limited mechanical space
- Low profile, fits in bulkhead and drop ceilings, slim height 9.75"
- Flexible CFM operational range
- Brackets included for easy installation
- No drains required
- Externally mounted e-box for quick access to circuit board and DIP switches
- Removable motor and electronic assembly for easy maintenance and service
- Convenient hinged door – no screws

NOTE: Front clearance of 25 in. (635 mm) is recommended for servicing unit.
All ducts use 5 in. (125 mm) round collars.
All units conform to CSA and UL standards.

DIMENSIONS

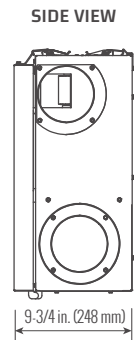
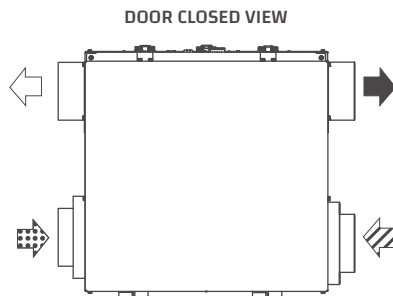
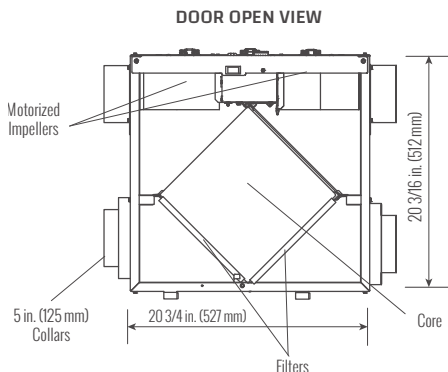

Standard Airflow:

- ⇨ Stale Air to Outside
- ⇦ Fresh Air from Outside
- ⇨ Stale Air from Inside
- ⇦ Fresh Air to Inside

Mirrored Airflow:

- ⇦ Fresh Air to Inside
- ⇨ Stale Air from Inside
- ⇦ Fresh Air from Outside
- ⇨ Stale Air to Outside

FEATURES

AUTO BALANCE

DXPL03 control allows airflow to be selected for both supply and exhaust air streams. Live air pressure measurements enable automatic and continuous adjustment of fan speeds to ensure constant user selected airflow.

TOTAL RECOVERY CORE

Cross-flow energy recover core transfers heat and water vapor between two airstreams. Easily removed for cleaning or service.

MOTORS AND BLOWERS

Each airstream has an independent centrifugal high efficiency ECM blower with multiple fan speed operation.

MERV 6 FILTERS

Washable air filters in exhaust and supply airstreams.
MERV 13 Upgrade: 65-195-6R.

MOUNTING

Mounting brackets supplied for ceiling installation.

DEFROST

Supply air shuts off to defrost core with warm exhaust air at high speed. Drains not required.

CASE

22 gauge prepainted galvanized steel for superior corrosion resistance, insulated to prevent exterior condensation.

ELECTRONICS

The optional control can be wall mounted in a central location of the home. 3 wire 20 gauge (min.) 100 ft length (max.).

OPTIONAL FEATURES

Hardwired, mirrored, and Fault Indication Display (FID) configurations are available.

Weight: 34 lbs (15.5 KG) • Shipping Weight: 36 lbs (16 KG)



SPECIFICATIONS

MODEL:	METRO 120 ERV-ECM-AB
VOLTAGE:	120 V
FREQUENCY:	60 Hz
WATTS @ 49 CFM (23 L/S):	22 W
CURRENT:	1.4 A
AIRFLOW @ 0.3:	117 CFM
WEIGHT:	34 lbs / 15.5 kg
DRAIN:	No
MCA:	2.0 A
MOP:	15 A
WARRANTY:	Units carry a 5 year warranty on the ERV core and a 5 year replacement parts warranty.

PERFORMANCE

IN. W.G. (PA)	0.2 (50) CFM (L/s)	0.3 (75) CFM (L/s)	0.4 (100) CFM (L/s)	0.5 (125) CFM (L/s)	0.6 (150) CFM (L/s)	0.7 (175) CFM (L/s)	0.8 (200) CFM (L/s)	0.9 (225) CFM (L/s)
Net Supply Airflow	123 (58)	117 (55)	108 (51)	97 (46)	87 (41)	74 (35)	57 (27)	40 (19)
Gross Supply Airflow	125 (59)	119 (56)	110 (52)	100 (47)	89 (42)	74 (35)	59 (28)	40 (19)
Gross Exhaust Airflow	121 (57)	117 (55)	110 (52)	104 (49)	93 (44)	78 (37)	57 (27)	28 (13)

Sensible Effectiveness (ASE)
@ 49 CFM (23 L/s) 32°F (0°C) 79%

Sensible Efficiency (SRE)
@ 49 CFM (23 L/s) 32°F (0°C) 72%

Total Efficiency (TRE)
@ 49 CFM (23 L/s) 95°F (35°C) 51%

