



RNC 155 2019*
148 CFM @ 0.3 (75) IN. W.G. (PA)

DOOR PORT BALANCING & 3 SELECT HIGH-SPEED SETTINGS. FEATURING OUR PATENTED HEX CORE

- High Efficiency Hex Core
- Door Port Balancing & Adjustable Dampers
- Outstanding Cold Weather Performance
- Energy Star: This product earned the ENERGY STAR® by meeting strict energy efficiency guidelines set by Natural Resources Canada and the US EPA. It meets ENERGY STAR® requirements only when used in Canada

*2019 denotes Energy Star certification, not manufacture date.

NOTE: Front clearance of 25 in. (635 mm) is recommended for servicing unit.
All ducts use 6 in. (152 mm) round collars.
Balancing dampers are located in all air streams.
All units conform to CSA and UL standards.

DIMENSIONS

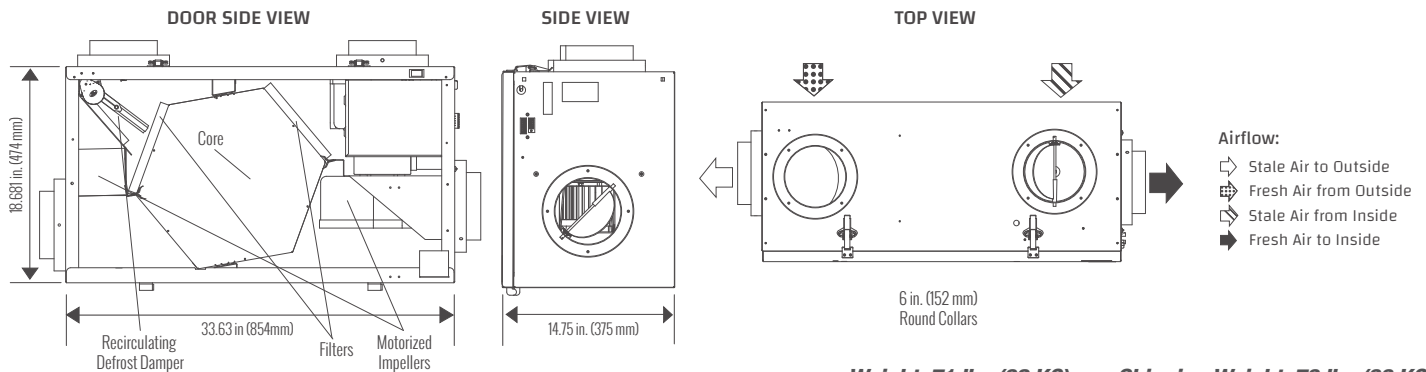

Weight: 71 lbs (32 KG) • Shipping Weight: 73 lbs (33 KG)

FEATURES

THERMALLY CONDUCTIVE HEX CORE

Counter-flow heat recovery core transfers heat between two airstreams. It is easily removed for cleaning or service.

MOTORS AND BLOWERS

Each airstream has one centrifugal blower driven by a common PSC motor, with multiple fan speed operations.

MERV 6 FILTERS

Washable air filters in exhaust and supply airstreams.
MERV 13 Upgrade: 65-195-6R.

MOUNTING

Four threaded inserts at corners of the cabinet designed to accept the "S" hooks and hanging straps supplied with the unit

DEFROST

Intelligent recirculating damper defrost system.

CASE

22 gauge prepainted galvanized steel for superior corrosion resistance, insulated to prevent exterior condensation. Drain connections 2 - 1/2 in. (12 mm) OD. Balancing ports are located on door.

INSTALLER SELECTABLE HIGH SPEED SETTINGS

Adjustable DIP switches are located on the circuit board, Hi3 is the factory setting. Refer to the installation manual for adjustment instructions.

ELECTRONICS

The optional control can be wall mounted in a central location of the home. 3 wire 20 gauge (min.) 100 ft length (max.).

LIFEBREATH® RNC 155 2019*

Indoor Air Systems HEAT RECOVERY VENTILATOR

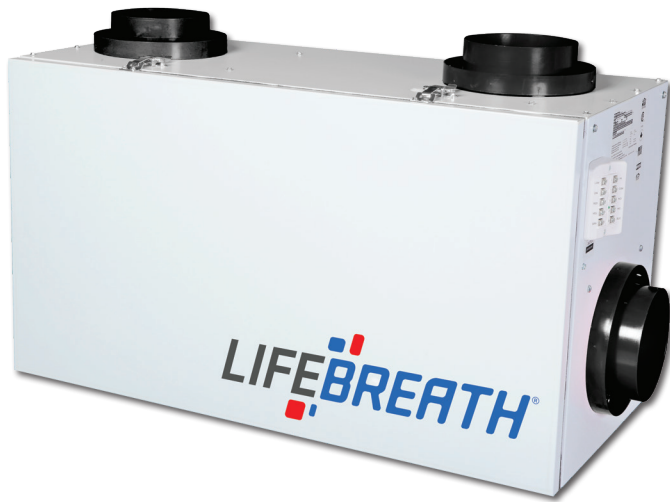

SPECIFICATIONS

MODEL:	RNC 155 2019*
VOLTAGE:	120 V
FREQUENCY:	60 Hz
WATTS @ 64 CFM (30 L/S):	72 W
CURRENT:	1.4 A
AIRFLOW @ 0.3:	148 CFM
WEIGHT:	71 lbs / 32 kg
DRAIN:	Yes
MCA:	2.0 A
MOP:	15 A
WARRANTY:	Units carry a lifetime warranty on the HRV core and a 5 year replacement parts warranty.



PERFORMANCE

IN. W.G. (PA)	0.1 (25) CFM (L/s)	0.2 (50) CFM (L/s)	0.3 (75) CFM (L/s)	0.4 (100) CFM (L/s)	0.5 (125) CFM (L/s)
Net Supply Airflow	170 (80)	159 (75)	148 (70)	138 (65)	123 (58)
Gross Supply Airflow	180 (85)	167 (79)	157 (74)	146 (69)	131 (62)
Gross Exhaust Airflow	186 (88)	172 (81)	157 (74)	133 (63)	83 (39)

***Sensible Efficiency (ASE)**
@ 59 CFM (28 L/s) 32°F (0°C) 85%

Sensible Efficiency (SRE)
@ 64 CFM (30 L/s) 32°F (0°C) 75%

Sensible Efficiency (SRE)
@ 68 CFM (32 L/s) -13°F (-25°C) 70%

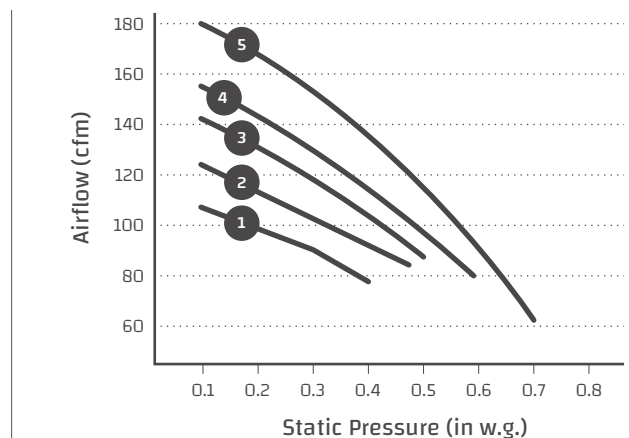

* Not an HVI certified data point