

LIFEBREATH® RNC5-TPF

Indoor Air Systems **HEAT RECOVERY VENTILATOR**



RNC5-TPF
180 CFM @ 0.3 (75) IN. W.G. (PA)

COMBINING GREAT PERFORMANCE IN A COMPACT DESIGN WITH VERY COMPETITIVE PRICING

- Cross Flow Core
- Door Port Balancing & Adjustable Dampers
- Top Ported
- Excellent Low Temperature Performance

NOTE: Front clearance of 25 in. (635 mm) is recommended for servicing unit.
All ducts use 5 in. (125 mm) oval collars.
Balancing dampers are located on all collars.
All units conform to CSA and UL standards.

DIMENSIONS

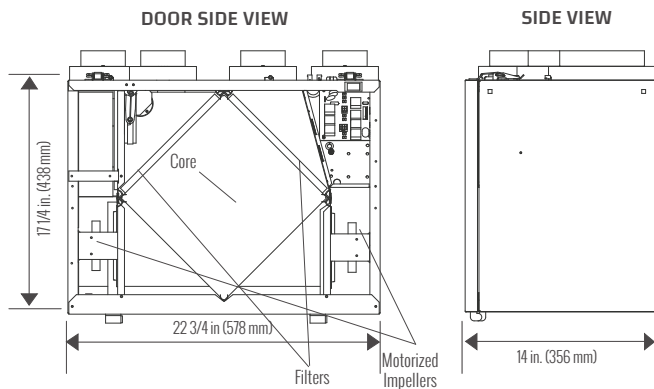

Airflow:

- ➡ Stale Air to Outside
- ➡ Fresh Air from Outside
- ➡ Stale Air from Inside
- ➡ Fresh Air to Inside

FEATURES

THERMALLY CONDUCTIVE HEX CORE

Cross-flow heat recovery core transfers heat between the two airstreams. It is easily removed for cleaning or service.

MOTORS AND BLOWERS

Each airstream has one motorized impeller with multiple fan speed operations.

MERV 6 FILTERS

Washable air filters in exhaust and supply airstreams.
MERV 13 Upgrade: 65-195-6R.

MOUNTING

Four threaded inserts at corners of the cabinet designed to accept the "S" hooks and hanging straps supplied with the unit.

DEFROST

Fan defrost. Temperature sensor activated, periodically shuts down supply motor.

CASE

22 gauge prepainted galvanized steel for superior corrosion resistance. Insulated to prevent exterior condensation. Drain connections 2 - 1/2 in. (12 mm) OD. Balancing ports are located on door.

INSTALLER SELECTABLE HIGH SPEED SETTINGS

Adjustable DIP switches are located on the circuit board, Hi3 is the factory setting. Refer to the installation manual for adjustment instructions.

ELECTRONICS

The optional control can be wall mounted in a central location of the home. 3 wire 20 gauge (min.) 100 ft length (max.).

Weight: 51 lbs (23 KG) • Shipping Weight: 54 lbs (25 KG)

LIFEBREATH® RNC5-TPF

Indoor Air Systems HEAT RECOVERY VENTILATOR



SPECIFICATIONS

MODEL:	RNC5-TPF
VOLTAGE:	120 V
FREQUENCY:	60 Hz
WATTS @ 64 CFM (30 L/S):	68 W
CURRENT:	1.2 A
AIRFLOW @ 0.3:	180 CFM
WEIGHT:	57 lbs / 25.8 kg
DRAIN:	Yes
MCA:	2.0 A
MOP:	15 A
WARRANTY:	Units carry a lifetime warranty on the HRV core and a 5 year replacement parts warranty.



PERFORMANCE

IN. W.G. (PA)	0.2 (50) CFM (L/s)	0.3 (75) CFM (L/s)	0.4 (100) CFM (L/s)	0.5 (125) CFM (L/s)	0.6 (150) CFM (L/s)	0.7 (175) CFM (L/s)	0.8 (200) CFM (L/s)	0.9 (225) CFM (L/s)	1.0 (250) CFM (L/s)
Net Supply Airflow	191 (90)	180 (85)	172 (81)	161 (76)	153 (72)	142 (67)	133 (63)	123 (58)	112 (53)
Gross Supply Airflow	191 (90)	182 (86)	172 (81)	163 (77)	153 (72)	142 (67)	133 (63)	123 (58)	112 (53)
Gross Exhaust Airflow	193 (91)	182 (86)	172 (81)	161 (76)	148 (70)	138 (65)	125 (59)	112 (53)	102 (48)

*Sensible Effectiveness (ASE) @ 64 CFM (30 L/s)	32°F (0°C)	74%
*Sensible Effectiveness (ASE) @ 95 CFM (45 L/s)	32°F (0°C)	71%
*Sensible Effectiveness (ASE) @ 117 CFM (55 L/s)	32°F (0°C)	69%
Sensible Efficiency (SRE) @ 95 CFM (45 L/s)	32°F (0°C)	62%
Sensible Efficiency (SRE) @ 117 CFM (55 L/s)	32°F (0°C)	61%
Sensible Efficiency (SRE) @ 70 CFM (33 L/s)	-13°F (-25°C)	56%

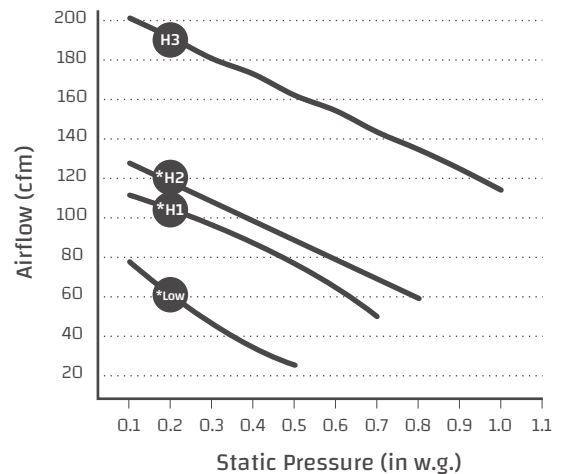

* Not an HVI certified data point