

100 ECM HEAT RECOVERY VENTILATOR



ENGINEERING DATA

THERMALLY CONDUCTIVE, PATENTED ALUMINUM CORE

The counter-flow heat recovery core transfers heat between the two airstreams. It is easily removed for cleaning or service.

MOTORS AND BLOWERS

High efficiency electronic commutate ECM motor, for maximum energy savings. Each airstream has one centrifugal blower, with multiple fanspeed operations driven by one double shaft motor.

FILTERS

Washable antimicrobial MERV 6 air filters in exhaust and supply airstreams.

MOUNTING

Four threaded inserts at corners of the cabinet designed to accept the "s" hooks and hanging straps supplied with the unit.

DEFROST

Recirculating damper defrost system.

CASE

Twenty gauge prepainted galvanized steel for superior corrosion resistance. Insulated to prevent exterior condensation. Drain connections 2 - 1/2 in. (12 mm) OD. Balancing ports are located on door.

ELECTRONICS

The DXPLO2 control included with the unit can be wall mounted in a central location of the home. 3 wire 20 gauge (min.) 100 ft length (max.).

WARRANTY

Units carry a lifetime warranty on the HRV core and a 5 year replacement parts warranty.

OPTIONAL ACCESSORIES:

Weather Hood

99-185
99-186
99-187



TechGrille

99-EAG4
99-EAG5
99-EAG6
99-EAG8



Terminator Fitting

99-TM4
99-TM5
99-TM6



Wireless 20/40/60 Min Timer

99-DETO2



LIFEBREATH CONTROL OPTIONS

FEATURES	99-DXPLO2	99-BC02	99-BC03	99-BC04
5 speed fan operation on each mode	✓			
2 speed fan operation (Low/High)		✓		✓
Continuous low speed fan operation			✓	
Humidity control through adjustable Dehumidistat	✓	✓	✓	
Large digital LCD screen	✓			
LED status indicator lights		✓	✓	✓
Continuous Ventilation	✓		✓	
Continuous Recirculation	✓		✓	
20 ON/40 OFF	✓			
10 ON/50 OFF	✓			
20 ON/40 Recirculation	✓		✓	✓
20/40/60 min. High speed override button	✓			
Compatible with 99-DETO2 Wireless Timer	✓	✓	✓	✓
3 wire connection	✓	✓	✓	✓

TIMER OPTIONS

99-DETO1 - Lifebreath 20/40/60 Minute Timer
Initiates high speed Ventilation for 20, 40 or 60 minutes. 3 wire connection.

99-DETO2 Wireless Lifebreath 20/40/60 Minute Timer
Initiates high speed Ventilation for 20, 40 or 60 minutes. Wirelessly connects to main control for ease of installation. 40' approximate range. Exclusive to Lifebreath.

99-RX02 - Wireless Lifebreath Repeater
Extends range of 99-DETO2 Wireless Timers. Plugs into 120V power outlet. Wirelessly connects to main control and 99-DETO2. Install at halfway point between timer and main wall control if timer is out of range.



99-DXPLO2



99-DETO2

LIFEBREATH
Indoor Air Systems

www.lifebreath.com

100 ECM HEAT RECOVERY VENTILATOR



PERFORMANCE (HVI CERTIFIED)

IN. W.G. (PA)	0.1 (25) CFM (L/s)	0.2 (50) CFM (L/s)	0.3 (75) CFM (L/s)	0.4 (100) CFM (L/s)	0.5 (125) CFM (L/s)	0.6 (150) CFM (L/s)
Net Supply Airflow	161 (76)	143 (68)	129 (61)	114 (54)	97 (46)	78 (37)
Gross Supply Airflow	165 (78)	147 (69)	131 (62)	117 (55)	102 (48)	81 (38)
Gross Exhaust Airflow	229 (108)	215 (101)	210 (99)	203 (96)	184 (87)	142 (67)

ELECTRICAL SPECIFICATIONS	
VAC @ 60Hz	120
Watts / Low Speed	40
Watts / High Speed	115
Amp Rating	1.75

Sensible Effectiveness (ASE) @ 64 CFM (30 L/s)	32°F (0°C)	78%
Sensible Efficiency (SRE) @ 64 CFM (30 L/s)	32°F (0°C)	71%
Sensible Efficiency (SRE) @ 95 CFM (45 L/s)	32°F (0°C)	69%
Sensible Efficiency (SRE) @ 68 CFM (32 L/s)	-13°F (-25°C)	64%

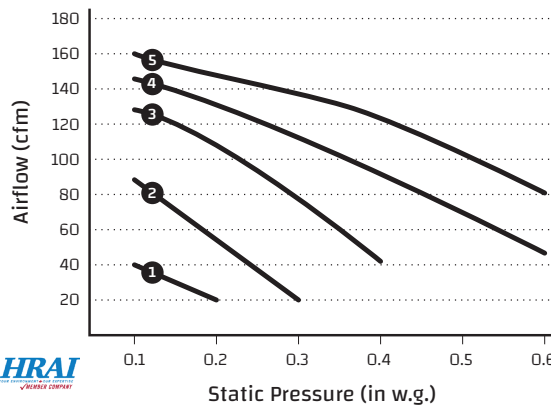

WEIGHT:
71 LBS (32 KG)

SHIPPING WEIGHT:
73 LBS (33 KG)

NOTE:

Front clearance of 25 in. (635 mm) is recommended for servicing unit. All ducts use 6 in. (152 mm) round collars. Balancing dampers are located in all air streams.



DIMENSIONS

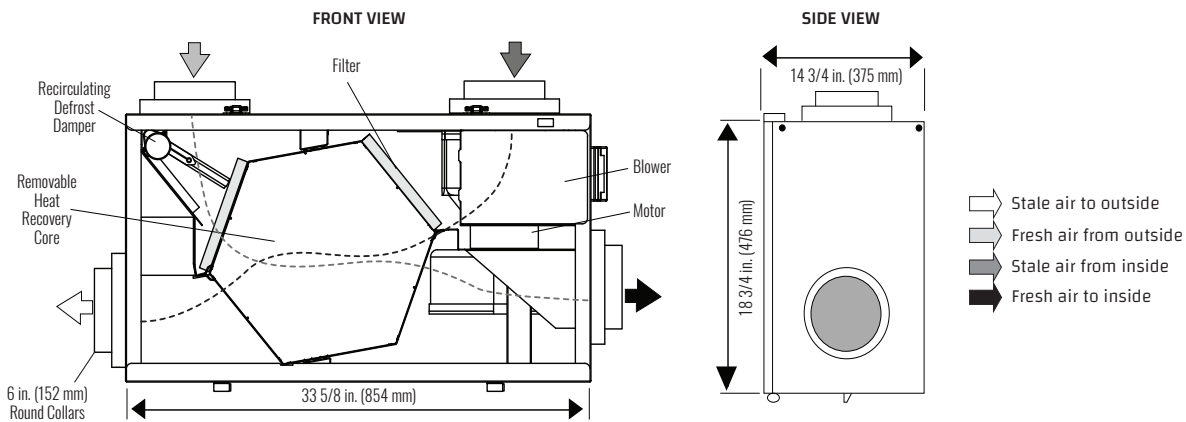

Date: _____

Tag: _____

Project: _____ Qty: _____

Engineer: _____

Control: _____

Contractor: _____

Supplier: _____

Quote #: _____

Submitted By: _____

Timer: _____ Timer Qty: _____

WARRANTY

Units carry a lifetime warranty on the HRV core and a 5 year replacement parts warranty.

All units conform to CSA and UL standards



www.lifebreath.com