

30 ERV

ENERGY RECOVERY VENTILATOR

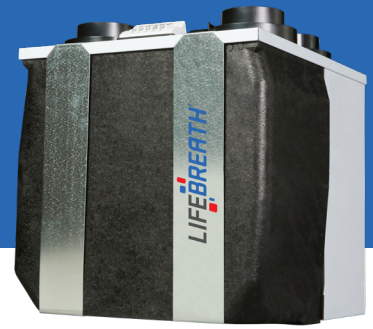

SUPERIOR PERFORMANCE IN A SMALL PACKAGE

Our smallest unit to date. Ideal for small homes and town homes with tight space requirements. Features a top port design, door port balancing, 4 in. duct connections and our ERV core.

- Enthalpy energy exchange core
- Adjustable dampers
- Top ported, super compact design

ENGINEERING DATA:

TOTAL RECOVERY CORE

Cross-flow energy recover core transfers heat and water vapor between two airstreams. Easily removed for cleaning or service.

MOTORS AND BLOWERS

Each airstream has an independent motorized impeller with multiple fan speed operation.

FILTERS

Washable air filters in exhaust and supply airstreams.

MOUNTING

Hanging straps supplied.

DEFROST

Supply air shuts off to defrost core with warm exhaust air at high speed. Drains not required.

CASE

20 gauge prepainted galvanized steel for superior corrosion resistance, insulated to prevent exterior condensation.

INSTALLER SELECTABLE HIGH SPEED SETTINGS

Adjustable DIP switches are located on the circuit board, Hi3 is the factory setting. Refer to the installation manual for the adjustment instructions.

ELECTRONICS

Main control can be wall mounted in a central location. 3 wire 20 gauge (min.) 100 ft. length (max.)

OPTIONAL ACCESSORIES:

Dual Hood
99-190
99-194



Weather Hood
99-185
99-186
99-187



TechGrille
99-EAG4
99-EAG5
99-EAG6
99-EAG8



Terminator Fitting
99-TM4
99-TM5
99-TM6



LIFEBREATH DXPL-O3 FEATURES

5 speed fan operation on each mode	✓
2 speed fan operation (Low/High)	✓
Continuous low speed fan operation	✓
Humidity control through adjustable Dehumidistat	✓
Large digital LCD screen	✓
Continuous Ventilation	✓
Continuous Recirculation	✓
20 ON/40 OFF	✓
10 ON/50 OFF	✓
20 ON/40 Recirculation	✓
20/40/60 min. High speed override button	✓
Compatible with 99-DET02 Wireless Timer	✓
3 wire connection	✓

TIMER OPTIONS

99-DET01 - 20/40/60 Minute Timer

Initiates high speed ventilation for 20, 40 or 60 minutes. 3 wire connection.

99-DET02 - 20/40/60 Minute Timer

Initiates high speed ventilation for 20, 40 or 60 minutes. Wirelessly connects to main control for ease of installation. 40 ft approximate range.

99-RX02 - Wireless Repeater

Extends range of 99-DET02 Wireless Timers. Plugs into 120V power outlet. Wirelessly connects to main control and 99-DET02. Install at halfway point between timer and main wall control if timer is out of range.



99-DXPLO3



99-DET01



99-DET02



99-RX02

*Recirculation features not available on fan defrost models.

30 ERV

ENERGY RECOVERY VENTILATOR

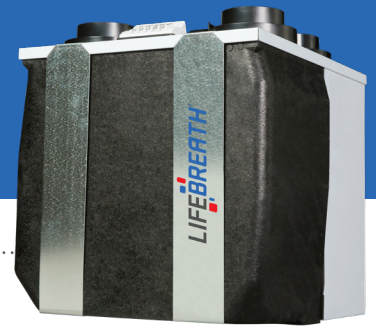

PERFORMANCE

IN. W.G. (PA)	0.1 (25) CFM (L/s)	0.2 (50) CFM (L/s)	0.3 (75) CFM (L/s)	0.4 (100) CFM (L/s)	0.5 (125) CFM (L/s)	0.6 (150) CFM (L/s)	0.7 (175) CFM (L/s)
Net Supply Airflow	72 (34)	68 (32)	63 (30)	57 (27)	50 (24)	43 (20)	36 (17)

ELECTRICAL SPECIFICATIONS	
VAC @ 60Hz	120
Watts / Low Speed	44
Watts / High Speed	57
Amp Rating	0.48

Sensible Effectiveness (ASE) @ 55 CFM (26 L/s)	32°F (0°C)	78%
Sensible Efficiency (SRE) @ 55 CFM (26 L/s)	32°F (0°C)	70%
Total Efficiency (TRE) @ 63 CFM (30 L/s)	95°F (35°C)	48%

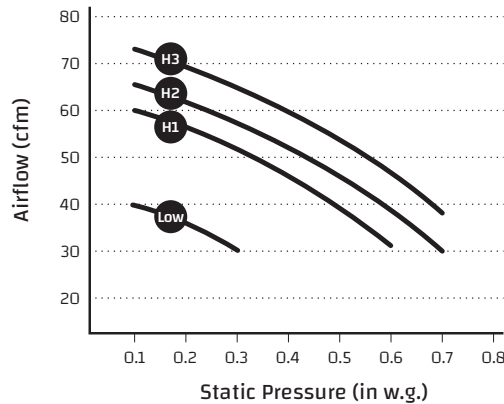

WEIGHT:
33 LBS (15 KG)

SHIPPING WEIGHT:
36 LBS (16 KG)

NOTE:
Front clearance of 25 in. (635 mm) is recommended for servicing unit. All ducts use 4 in. (102 mm) round collars. Balancing dampers are located in all air streams.

DIMENSIONS

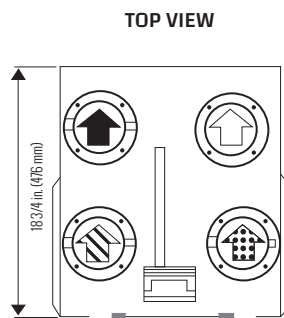
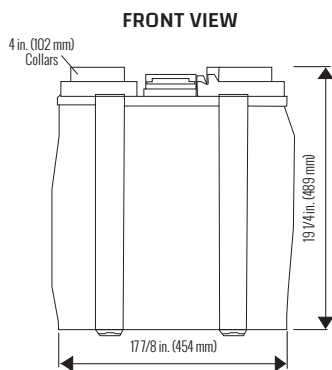

Airflow:

- Stale Air to Outside
- Fresh Air from Outside
- Stale Air from Inside
- Fresh Air to Inside

Date: _____

Contractor: _____

Tag: _____

Supplier: _____

Project: _____ Qty: _____

Quote #: _____

Engineer: _____

Submitted By: _____

Control: _____

Timer: _____ Timer Qty: _____

WARRANTY

Units carry a 5 year warranty on the enthalpic (ERV) core and a 5 year replacement parts warranty.

All units conform to CSA and UL standards



www.lifebreath.com