



TFP 3000 HEPA RTO

REVOLUTIONIZING HOME AIR CLEANING

- 99.97% efficient at .3 microns.
- A human hair is 100 microns wide.
- Spores and pollen are all larger than 8 microns.
- A micron is 1/1000 of a millimeter, or less than 1/2 of 1/10,000 of an inch.

TFP 3000 HEPA RTO PARTICLE CAPTURE RATE

Particle Size (microns)

.3 or more

Percentage Caught

99.7%

DIMENSIONS

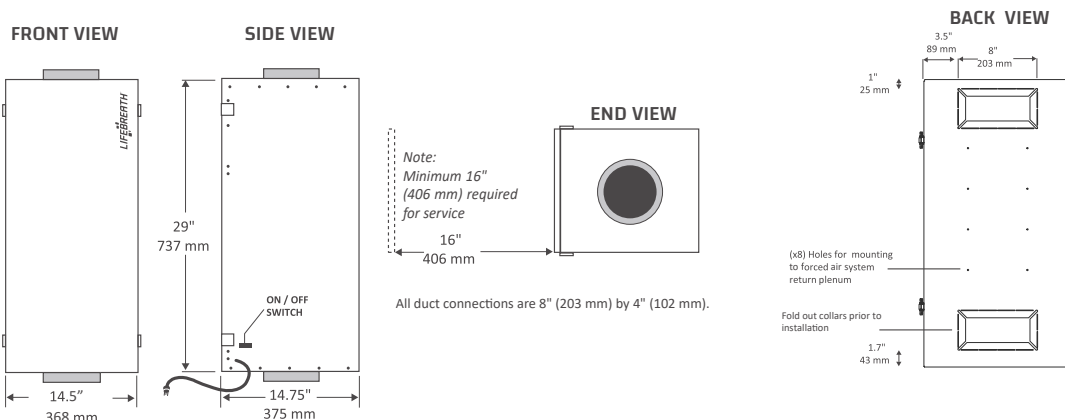

ENGINEERING DATA

MOTORS AND BLOWERS

High efficiency PSC Motor - 150 cfm @ .4" WC 110 watts - 120 VAC. Standard three prong plug to receptacle. The TFP is equipped with a standard power supply of 5'5" (1.6 meters) cable.

COLLECTOR AND FILTER

One replaceable TFP collector and one replaceable HEPA filter. Easy to remove for cleaning and replacement. Annual inspection recommended.

MOUNTING THE AIR CLEANER - 4 OPTIONS

The TFP-3000-RTO air cleaner is to be mounted directly to the return duct of the forced air system.

OPTIONS

65-502R Replacement HEPA Filter

65-503R Replacement TFP Collector

WARRANTY

Units carry a 5 year replacement parts warranty. No warranty on collector / filter.

