

# LIFEBREATH® 1200 POOL

Indoor Air Systems **HEAT RECOVERY VENTILATOR**



1200 POOL

## DESIGNED FOR INDOOR POOL APPLICATIONS

- Contains 3 AHRI 1060 Certified 68-222 HEX Cores
- Field switch side access panel allowing either side maintenance access.
- Upgraded for pool applications, lowest cost compared to other dehumidification installations.
- Microprocessor circuit board with built in interlock contacts
- Field reversible

NOTE: Front clearance of 25 in. (635 mm) is recommended for servicing unit. All units conform to CSA and UL standards.

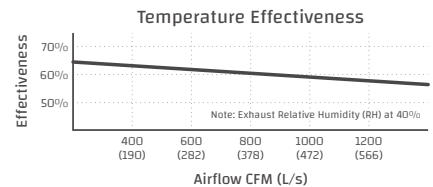
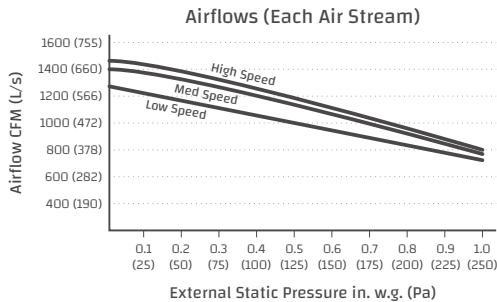

## DIMENSIONS

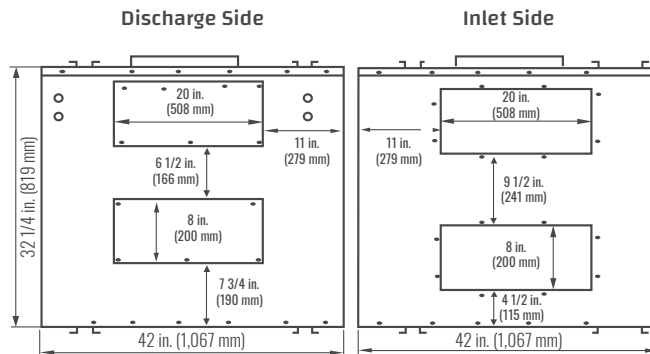
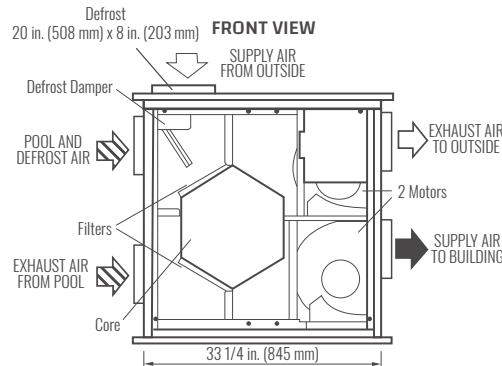

- Airflow:
- ⇐ Stale Air to Outside
  - ⇐ Fresh Air from Outside
  - ⇐ Stale Air from Inside
  - ⇐ Fresh Air to Inside

## FEATURES

### CORES

Modular (3 section) patented aluminum heat recovery cores arranged for efficient counter-flow ventilation.

### MOTORS

Two PSC, 3 speed single shafted motors. 120 VAC, 9.4 Amps each (18.8 Amps total on high speed). 1/2 HP, 1625 RPM. 2256 Watts on high speed. MCA: 47 MOP: 30.

### BLOWERS

Slide easily in / out of unit. Centrifugal type rated at at 1200 cfm (566 L/s) free air delivery.

### MERV 6 FILTERS

Washable air filters in exhaust and supply air streams. MERV 13 Upgrade: 65-195-6R.

### MOUNTING

Unit to be set on support brackets hung by threaded rod type apparatus (brackets and rod not provided), or placed on vibrations isolation pads.

### DEFROST

Supply bypass routes indoor air to defrost core.

### CASE

Unit has front and back access doors. Electrical panel can be switched to either front or back, giving installer flexibility in duct direction. 22 gauge prepainted galvanized steel (G60) for superior corrosion resistance. Insulated with elastomeric insulation. Drain connections: two - 1/2" (12mm) O.D.

### ELECTRONICS

Integrated microprocessor circuit board. Built-in interlock contacts. BC02 Basic Control included.

### WARRANTY

Units carry a 15 year warranty on HRV core and 2 year replacement parts warranty.