

180 ERVD-FID
178 CFM @ 0.3 (75) IN. W.G. (PA)



SUPERIOR PERFORMANCE
TOP CHOICE ERV

- **AUTO BALANCING**
- **DXPL03 Digital Wall Control** included, for easy programmability.
- **Enthalpy energy exchange core**
- **Smart damper with integrated circuit board**
- **High Efficiency EC motors**
- **Energy Star Certified**
- **-25°C HVI Cold Weather Certified**
- **Energy Star: This product earned the ENERGY STAR® by meeting strict energy efficiency guidelines set by Natural Resources Canada and the US EPA. It meets ENERGY STAR® requirements only when used in Canada.**

NOTE: Front clearance of 25 in. (635 mm) is recommended for servicing unit. All ducts use 5 in. (125 mm) round collars. Balancing dampers are located on all collars. All units conform to CSA and UL standards.

DIMENSIONS

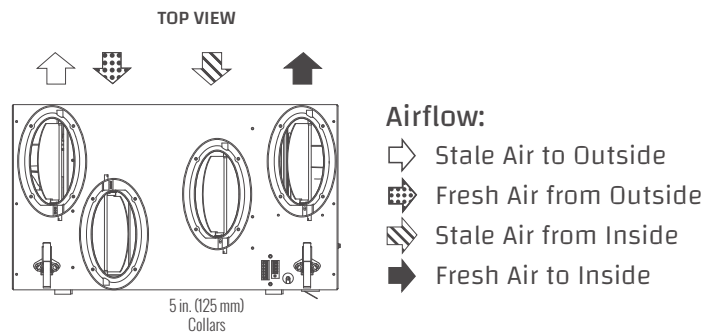
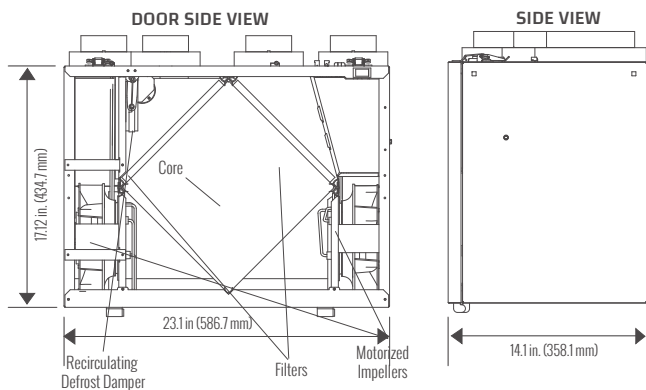

FEATURES

AUTO BALANCE

DXPL03 control allows airflow to be selected for both supply and exhaust air streams. Live air pressure measurements enable automatic and continuous adjustment of fan speeds to ensure constant user selected airflow.

FAULT INDICATION DISPLAY (FID)

Title 24 Compliant. A FID enabled HRV or ERV is capable of displaying error codes for certain types of faults which impact operation of the system.

TOTAL RECOVERY CORE

Cross-flow energy recover core transfers heat and water vapor between two airstreams. Easily removed for cleaning or service.

MOTORS AND BLOWERS

High Efficiency EC motors. Each airstream has an independent motorized impeller with multiple fan speed operation.

MERV 6 FILTERS

*Washable air filters in exhaust and supply airstreams. **MERV 13 Upgrade: 65-192-6R.***

MOUNTING

Adjustable hanging straps supplied.

DEFROST

Recirculating damper defrost system.

CASE

22 gauge prepainted galvanized steel for superior corrosion resistance, insulated to prevent exterior condensation.

ELECTRONICS

The main control can be wall mounted in a central location of the home. 3 wire 20 gauge (min.) 100 ft length (max.).

Weight: 53 lbs (24 KG) • Shipping Weight: 56 lbs (25 KG)

LIFEBREATH[®] 180 ERVD-FID

Indoor Air Systems ENERGY RECOVERY VENTILATOR

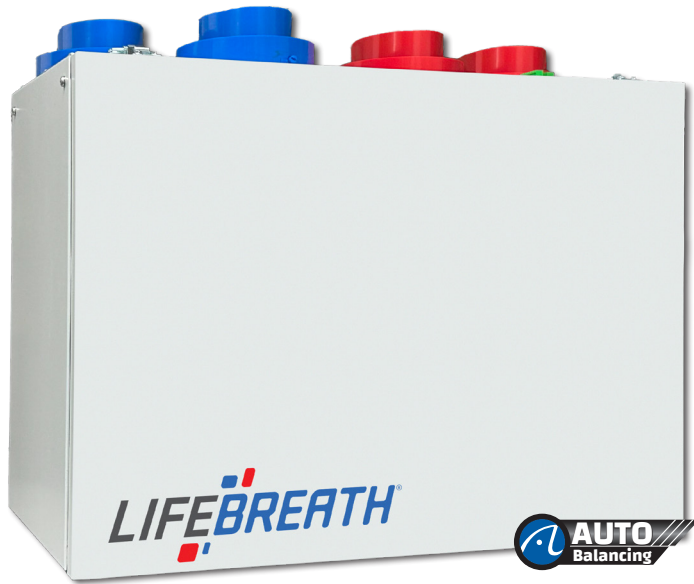

SPECIFICATIONS

MODEL:	180 ERVD-FID
VOLTAGE:	120 V
FREQUENCY:	60 Hz
WATTS @ 67 CFM (32 L/S):	26 W
CURRENT:	1.86 A
AIRFLOW @ 0.3:	178 CFM
WEIGHT:	53 lbs / 24 kg
DRAIN:	Optional
MCA:	3.0 A
MOP:	15 A
WARRANTY:	Units carry a 5 year warranty on the ERV core and a 5 year replacement parts warranty.



PERFORMANCE

IN. W.G. (PA)	0.2 (50) CFM (L/s)	0.3 (75) CFM (L/s)	0.4 (100) CFM (L/s)	0.5 (125) CFM (L/s)	0.6 (150) CFM (L/s)	0.7 (175) CFM (L/s)	0.8 (200) CFM (L/s)	0.9 (225) CFM (L/s)
Net Supply Airflow	186 (88)	178 (84)	172 (81)	165 (78)	159 (75)	153 (72)	144 (68)	136 (64)
Gross Supply Airflow	191 (90)	182 (86)	176 (83)	170 (80)	161 (76)	155 (73)	148 (70)	140 (66)
Gross Exhaust Airflow	182 (86)	174 (82)	165 (78)	159 (75)	153 (72)	146 (69)	140 (66)	133 (63)

Sensible Effectiveness (ASE) @ 68 CFM (32 L/s)	32°F (0°C)	83%
Sensible Efficiency (SRE) @ 68 CFM (32 L/s)	32°F (0°C)	77%
Sensible Efficiency (SRE) @ 95 CFM (45 L/s)	95°F (35°C)	71%
Sensible Efficiency (SRE) @ 114 CFM (54 L/s)	-13°F (-25°C)	60%
Total Efficiency (TRE) @ 66 CFM (31 L/s)	95°F (35°C)	50%

