



RNC6-ES
163 CFM @ 0.3 (75) IN. W.G. (PA)

5" DUCT CONNECTIONS, TOP PORT DESIGN, DOOR PORT BALANCING, AND 3 SELECT HIGH-SPEED SETTINGS

- Cross Flow Core
- Door Port Balancing & Adjustable Dampers
- Top Ported
- Excellent Low Temperature Performance
- Energy Star: This product earned the ENERGY STAR® by meeting strict energy efficiency guidelines set by Natural Resources Canada and the US EPA. It meets ENERGY STAR® requirements only when used in Canada

NOTE: Front clearance of 25 in. (635 mm) is recommended for servicing unit.
Round duct connections are 5 in. (127 mm).
Oval collars use 6 in. (152 mm) connections.
All units conform to CSA and UL standards.

DIMENSIONS

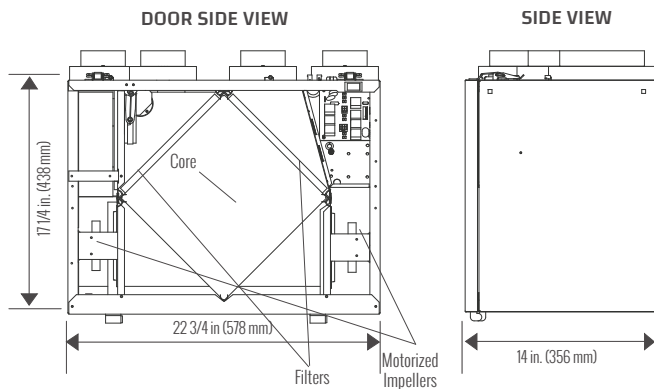

FEATURES

THERMALLY CONDUCTIVE HEX CORE

Cross-flow heat recovery core transfers heat between the two airstreams. It is easily removed for cleaning or service.

MOTORS AND BLOWERS

Each airstream has one motorized impeller with multiple fan speed operations.

MERV 6 FILTERS

Washable air filters in exhaust and supply airstreams.
MERV 13 Upgrade: 65-195-6R.

MOUNTING

Four threaded inserts at corners of the cabinet designed to accept the "S" hooks and hanging straps supplied with the unit.

DEFROST

Intelligent recirculating damper defrost system.

CASE

22 gauge prepainted galvanized steel for superior corrosion resistance. Insulated to prevent exterior condensation. Drain connections 2 - 1/2 in. (12 mm) OD. Balancing ports are located on door.

INSTALLER SELECTABLE HIGH SPEED SETTINGS

Adjustable DIP switches are located on the circuit board, Hi3 is the factory setting. Refer to the installation manual for adjustment instructions.

ELECTRONICS

The optional control can be wall mounted in a central location of the home. 3 wire 20 gauge (min.) 100 ft length (max.).

Airflow:

- ➡ Stale Air to Outside
- ➡ Fresh Air from Outside
- ➡ Stale Air from Inside
- ➡ Fresh Air to Inside

Weight: 51 lbs (23 KG) • Shipping Weight: 54 lbs (25 KG)



SPECIFICATIONS

MODEL:	RNC6-ES
VOLTAGE:	120 V
FREQUENCY:	60 Hz
WATTS @ 64 CFM (30 L/S):	47 W
CURRENT:	1.25 A
AIRFLOW @ 0.3:	163 CFM
WEIGHT:	51 lbs / 25.8 kg
DRAIN:	Yes
MCA:	2.0 A
MOP:	15 A
WARRANTY:	Units carry a lifetime warranty on the HRV core and a 5 year replacement parts warranty.



PERFORMANCE

IN. W.G. (PA)	0.1 (25) CFM (L/s)	0.2 (50) CFM (L/s)	0.3 (75) CFM (L/s)	0.4 (100) CFM (L/s)	0.5 (125) CFM (L/s)	0.6 (150) CFM (L/s)	0.7 (175) CFM (L/s)	0.8 (200) CFM (L/s)	0.9 (225) CFM (L/s)
Net Supply Airflow	186 (88)	174 (82)	163 (77)	150 (71)	140 (66)	127 (60)	114 (54)	102 (48)	89 (42)
Gross Supply Airflow	191 (90)	178 (84)	167 (79)	155 (73)	142 (67)	129 (61)	117 (55)	104 (49)	89 (42)
Gross Exhaust Airflow	182 (86)	170 (80)	159 (75)	146 (69)	136 (64)	123 (58)	110 (52)	97 (46)	83 (39)

Sensible Effectiveness (ASE) @ 64 CFM (30 L/s)	32°F (0°C)	75%
Sensible Efficiency (SRE) @ 64 CFM (30 L/s)	32°F (0°C)	65%
Sensible Efficiency (SRE) @ 70 CFM (33 L/s)	-13°F (-25°C)	60%

